

1

Introduction: Modern Wind Energy and its Origins

The re-emergence of the wind as a significant source of the world's energy must rank as one of the significant developments of the late 20th century. The advent of the steam engine, followed by the appearance of other technologies for converting fossil fuels to useful energy, would seem to have forever relegated to insignificance the role of the wind in energy generation. In fact, by the mid 1950s that appeared to be what had already happened. By the late 1960s, however, the first signs of a reversal could be discerned, and by the early 1990s it was becoming apparent that a fundamental reversal was underway. That decade saw a strong resurgence in the worldwide wind energy industry, with installed capacity increasing over five-fold. The 1990s were also marked by a shift to large, megawatt-sized wind turbines, a reduction and consolidation in wind turbine manufacture, and the actual development of offshore wind power (see McGowan and Connors, 2000). During the start of the 21st century this trend has continued, with European countries (and manufacturers) leading the increase via government policies focused on developing domestic sustainable energy supplies and reducing pollutant emissions.

To understand what was happening, it is necessary to consider five main factors. First of all there was a need. An emerging awareness of the finiteness of the earth's fossil fuel reserves as well as of the adverse effects of burning those fuels for energy had caused many people to look for alternatives. Second, there was the potential. Wind exists everywhere on the earth, and in some places with considerable energy density. Wind had been widely used in the past, for mechanical power as well as transportation. Certainly, it was conceivable to use it again. Third, there was the technological capacity. In particular, there had been developments in other fields, which, when applied to wind turbines, could revolutionize the way they could be used. These first three factors were necessary to foster the re-emergence of wind energy, but not sufficient. There needed to be two more factors, first of all a vision of a new way to use the wind, and second the political will to make it happen. The vision began well before the 1960s with such individuals as Poul la Cour, Albert Betz, Palmer Putnam, and Percy Thomas. It was continued by Johannes Juul, E. W. Golding, Ulrich Hütter, and William Heronemus, but soon spread to others too numerous to mention. At the beginning of wind's re-emergence, the cost of energy

from wind turbines was far higher than that from fossil fuels. Government support was required to carry out research, development, and testing; to provide regulatory reform to allow wind turbines to interconnect with electrical networks; and to offer incentives to help hasten the deployment of the new technology. The necessary political will for this support appeared at different times and to varying degrees, in a number of countries: first in the United States, Denmark, and Germany, and now in much of the rest of the world.

The purpose of this chapter is to provide an overview of wind energy technology today, so as to set a context for the rest of the book. It addresses such questions as: What does modern wind technology look like? What is it used for? How did it get this way? Where is it going?

1.1 Modern Wind Turbines

A wind turbine, as described in this book, is a machine which converts the power in the wind into electricity. This is in contrast to a ‘windmill’, which is a machine which converts the wind’s power into mechanical power. As electricity generators, wind turbines are connected to some electrical network. These networks include battery-charging circuits, residential scale power systems, isolated or island networks, and large utility grids. In terms of total numbers, the most frequently found wind turbines are actually quite small – on the order of 10 kW or less. In terms of total generating capacity, the turbines that make up the majority of the capacity are, in general, rather large – in the range of 1.5 to 5 MW. These larger turbines are used primarily in large utility grids, at first mostly in Europe and the United States and more recently in China and India. A typical modern wind turbine, in a wind farm configuration, connected to a utility network, is illustrated in Figure 1.1. The turbine shown is a General Electric 1.5 MW and this manufacturer had delivered over 10 000 units of this model at the time of writing of this text.

To understand how wind turbines are used, it is useful to briefly consider some of the fundamental facts underlying their operation. In modern wind turbines, the actual conversion process uses the basic aerodynamic force of lift to produce a net positive torque on a rotating shaft, resulting first in the production of mechanical power and then in its transformation to electricity in a generator. Wind turbines, unlike most other generators, can produce energy only in response to the resource that is immediately available. It is not possible to store the wind and



Figure 1.1 Modern utility-scale wind turbine. Reproduced by permission of General Electric

use it at a later time. The output of a wind turbine is thus inherently fluctuating and non-dispatchable. (The most one can do is to limit production below what the wind could produce.) Any system to which a wind turbine is connected must, in some way, take this variability into account. In larger networks, the wind turbine serves to reduce the total electrical load and thus results in a decrease in either the number of conventional generators being used or in the fuel use of those that are running. In smaller networks, there may be energy storage, backup generators, and some specialized control systems. A further fact is that the wind is not transportable: it can only be converted where it is blowing. Historically, a product such as ground wheat was made at the windmill and then transported to its point of use. Today, the possibility of conveying electrical energy via power lines compensates to some extent for wind's inability to be transported. In the future, hydrogen-based energy systems may add to this possibility.

1.1.1 Modern Wind Turbine Design

Today, the most common design of wind turbine, and the type which is the primary focus of this book, is the horizontal axis wind turbine (HAWT). That is, the axis of rotation is parallel to the ground. HAWT rotors are usually classified according to the rotor orientation (upwind or downwind of the tower), hub design (rigid or teetering), rotor control (pitch vs. stall), number of blades (usually two or three blades), and how they are aligned with the wind (free yaw or active yaw). Figure 1.2 shows the upwind and downwind configurations.

The principal subsystems of a typical (land-based) horizontal axis wind turbine are shown in Figure 1.3. These include:

- The rotor, consisting of the blades and the supporting hub.
- The drive train, which includes the rotating parts of the wind turbine (exclusive of the rotor); it usually consists of shafts, gearbox, coupling, a mechanical brake, and the generator.
- The nacelle and main frame, including wind turbine housing, bedplate, and the yaw system.
- The tower and the foundation.
- The machine controls.
- The balance of the electrical system, including cables, switchgear, transformers, and possibly electronic power converters.

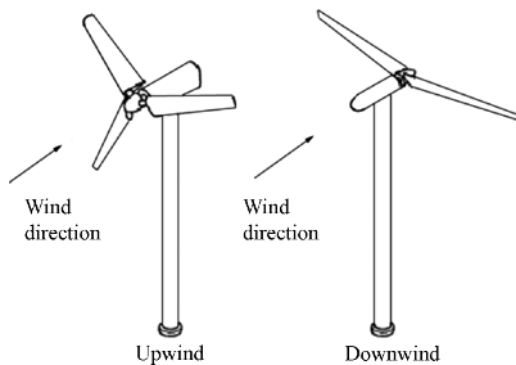

Figure 1.2 HAWT rotor configurations

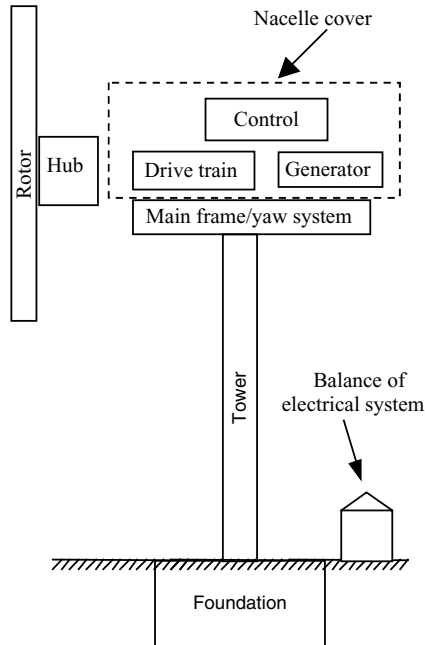

Figure 1.3 Major components of a horizontal axis wind turbine

The main options in wind turbine design and construction include:

- number of blades (commonly two or three);
- rotor orientation: downwind or upwind of tower;
- blade material, construction method, and profile;
- hub design: rigid, teetering, or hinged;
- power control via aerodynamic control (stall control) or variable-pitch blades (pitch control);
- fixed or variable rotor speed;
- orientation by self-aligning action (free yaw), or direct control (active yaw);
- synchronous or induction generator (squirrel cage or doubly fed);
- gearbox or direct drive generator.

A short introduction to and overview of some of the most important components follows. A more detailed discussion of the overall design aspects of these components, and other important parts of a wind turbine system, is contained in Chapters 3 through 9 of this book.

1.1.1.1 Rotor

The rotor consists of the hub and blades of the wind turbine. These are often considered to be the turbine's most important components from both a performance and overall cost standpoint.

Most turbines today have upwind rotors with three blades. There are some downwind rotors and a few designs with two blades. Single-blade turbines have been built in the past, but are no

longer in production. Some intermediate-sized turbines used fixed-blade pitch and stall control (described in Chapters 3, 6, 7 and 8). Most manufacturers use pitch control, and the general trend is the increased use of pitch control, especially in larger machines. The blades on the majority of turbines are made from composites, primarily fiberglass or carbon fiber reinforced plastics (GRP or CFRP), but sometimes wood/epoxy laminates are used. These subjects are addressed in more detail in the aerodynamics chapter (Chapter 3) and in Chapters 6 and 7.

1.1.1.2 Drive Train

The drive train consists of the other rotating parts of the wind turbine downstream of the rotor. These typically include a low-speed shaft (on the rotor side), a gearbox, and a high-speed shaft (on the generator side). Other drive train components include the support bearings, one or more couplings, a brake, and the rotating parts of the generator (discussed separately in the next section). The purpose of the gearbox is to speed up the rate of rotation of the rotor from a low value (tens of rpm) to a rate suitable for driving a standard generator (hundreds or thousands of rpm). Two types of gearboxes are used in wind turbines: parallel shaft and planetary. For larger machines (over approximately 500 kW), the weight and size advantages of planetary gearboxes become more pronounced. Some wind turbine designs use multiple generators, and so are coupled to a gearbox with more than one output shaft. Others use specially designed, low-speed generators requiring no gearbox.

While the design of wind turbine drive train components usually follows conventional mechanical engineering machine design practice, the unique loading of wind turbine drive trains requires special consideration. Fluctuating winds and the dynamics of large rotating rotors impose significant varying loads on drive train components.

1.1.1.3 Generator

Nearly all wind turbines use either induction or synchronous generators (see Chapter 5). These designs entail a constant or nearly constant rotational speed when the generator is directly connected to a utility network. If the generator is used with power electronic converters, the turbine will be able to operate at variable speed.

Many wind turbines installed in grid connected applications use squirrel cage induction generators (SQIG). A SQIG operates within a narrow range of speeds slightly higher than its synchronous speed (a four-pole generator operating in a 60 Hz grid has a synchronous speed of 1800 rpm). The main advantages of this type of induction generator are that it is rugged, inexpensive, and easy to connect to an electrical network. An increasingly popular option today is the doubly fed induction generator (DFIG). The DFIG is often used in variable-speed applications. It is described in more detail in Chapter 5.

An increasingly popular option for utility-scale electrical power generation is the variable-speed wind turbine. There are a number of benefits that such a configuration offers, including the reduction of wear and tear on the wind turbine and potential operation of the wind turbine at maximum efficiency over a wide range of wind speeds, yielding increased energy capture. Although there are a large number of potential hardware options for variable-speed operation of wind turbines, power electronic components are used in most variable-speed machines currently being designed. When used with suitable power electronic converters, either synchronous or induction generators of either type can run at variable speed.

1.1.1.4 Nacelle and Yaw System

This category includes the wind turbine housing, the machine bedplate or main frame, and the yaw orientation system. The main frame provides for the mounting and proper alignment of the drive train components. The nacelle cover protects the contents from the weather.

A yaw orientation system is required to keep the rotor shaft properly aligned with the wind. Its primary component is a large bearing that connects the main frame to the tower. An active yaw drive, always used with upwind wind turbines and sometimes with downwind turbines, contains one or more yaw motors, each of which drives a pinion gear against a bull gear attached to the yaw bearing. This mechanism is controlled by an automatic yaw control system with its wind direction sensor usually mounted on the nacelle of the wind turbine. Sometimes yaw brakes are used with this type of design to hold the nacelle in position, when not yawing. Free yaw systems (meaning that they can self-align with the wind) are often used on downwind wind machines.

1.1.1.5 Tower and Foundation

This category includes the tower itself and the supporting foundation. The principal types of tower design currently in use are the free-standing type using steel tubes, lattice (or truss) towers, and concrete towers. For smaller turbines, guyed towers are also used. Tower height is typically 1 to 1.5 times the rotor diameter, but in any case is normally at least 20 m. Tower selection is greatly influenced by the characteristics of the site. The stiffness of the tower is a major factor in wind turbine system dynamics because of the possibility of coupled vibrations between the rotor and tower. For turbines with downwind rotors, the effect of tower shadow (the wake created by air flow around a tower) on turbine dynamics, power fluctuations, and noise generation must be considered. For example, because of the tower shadow, downwind turbines are typically noisier than their upwind counterparts.

1.1.1.6 Controls

The control system for a wind turbine is important with respect to both machine operation and power production. A wind turbine control system includes the following components:

- **sensors** – speed, position, flow, temperature, current, voltage, etc.;
- **controllers** – mechanical mechanisms, electrical circuits;
- **power amplifiers** – switches, electrical amplifiers, hydraulic pumps, and valves;
- **actuators** – motors, pistons, magnets, and solenoids;
- **intelligence** – computers, microprocessors.

The design of control systems for wind turbine application follows traditional control engineering practices. Many aspects, however, are quite specific to wind turbines and are discussed in Chapter 8. Wind turbine control involves the following three major aspects and the judicious balancing of their requirements:

- Setting upper bounds on and limiting the torque and power experienced by the drive train.

- Maximizing the fatigue life of the rotor drive train and other structural components in the presence of changes in the wind direction, speed (including gusts), and turbulence, as well as start–stop cycles of the wind turbine.
- Maximizing the energy production.

1.1.1.7 Balance of Electrical System

In addition to the generator, the wind turbine system utilizes a number of other electrical components. Some examples are cables, switchgear, transformers, power electronic converters, power factor correction capacitors, yaw and pitch motors. Details of the electrical aspects of wind turbines themselves are contained in Chapter 5. Interconnection with electrical networks is discussed in Chapter 9.

1.1.2 Power Output Prediction

The power output of a wind turbine varies with wind speed and every wind turbine has a characteristic power performance curve. With such a curve it is possible to predict the energy production of a wind turbine without considering the technical details of its various components. The power curve gives the electrical power output as a function of the hub height wind speed. Figure 1.4 presents an example of a power curve for a hypothetical wind turbine.

The performance of a given wind turbine generator can be related to three key points on the velocity scale:

- **Cut-in speed:** the minimum wind speed at which the machine will deliver useful power.
- **Rated wind speed:** the wind speed at which the rated power (generally the maximum power output of the electrical generator) is reached.
- **Cut-out speed:** the maximum wind speed at which the turbine is allowed to deliver power (usually limited by engineering design and safety constraints).

Power curves for existing machines can normally be obtained from the manufacturer. The curves are derived from field tests, using standardized testing methods. As is discussed in

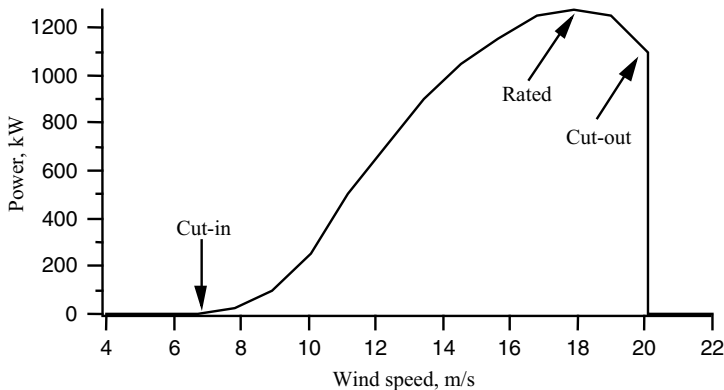

Figure 1.4 Typical wind turbine power curve

Chapter 7, it is also possible to estimate the approximate shape of the power curve for a given machine. Such a process involves determination of the power characteristics of the wind turbine rotor and electrical generator, gearbox gear ratios, and component efficiencies.

1.1.3 Other Wind Turbine Concepts

The wind turbine overview provided above assumed a topology of a basic type, namely one that employs a horizontal axis rotor, driven by lift forces. It is worth noting that a vast number of other topologies have been proposed, and in some cases built. None of these has met with the same degree of success as those with a horizontal-axis, lift-driven rotor. A few words are in order, however, to summarize briefly some of these other concepts. The closest runner up to the HAWT is the Darrieus vertical axis wind turbine (VAWT). This concept was studied extensively in both the United States and Canada in the 1970s and 1980s. An example of a VAWT wind turbine (Sandia 17 m design (SNL, 2009)) based on this concept is shown in Figure 1.5.

Despite some appealing features, Darrieus wind turbines had some major reliability problems and were never able to match corresponding HAWTs in cost of energy. However, it is possible that the concept could emerge again for some applications. For a summary of past work on this turbine design and other VAWT wind turbine designs the reader is referred to Paraschivoiu (2002), Price (2006), and the summary of VAWT work carried out by Sandia National Laboratories (SNL) in the US (2009).

Another concept that appears periodically is the concentrator or diffuser augmented wind turbine (see van Bussel, 2007). In both types of design, the idea is to channel the wind to increase the productivity of the rotor. The problem is that the cost of building an effective concentrator or diffuser, which can also withstand occasional extreme winds, has always been more than the device was worth.

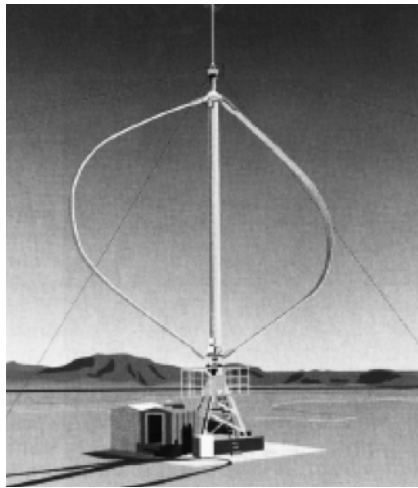

Figure 1.5 Sandia 17-meter Darrieus VAWT (Sandia National Laboratory, 2009)

Finally, a number of rotors using drag instead of lift have been proposed. One concept, the Savonius rotor, has been used for some small water-pumping applications. There are two fundamental problems with such rotors: (1) they are inherently inefficient (see comments on drag machines in Chapter 3), and (2) it is difficult to protect them from extreme winds. It is doubtful whether such rotors will ever achieve widespread use in wind turbines.

The reader interested in some of the variety of wind turbine concepts may wish to consult Nelson (1996). This book provides a description of a number of innovative wind systems. Reviews of various types of wind machines are given in Eldridge (1980) and Le Gouieries (1982). Some of the more innovative designs are documented in work supported by the US Department of Energy (1979, 1980). A few of the many interesting wind turbine concepts are illustrated in Figures 1.6 and 1.7.

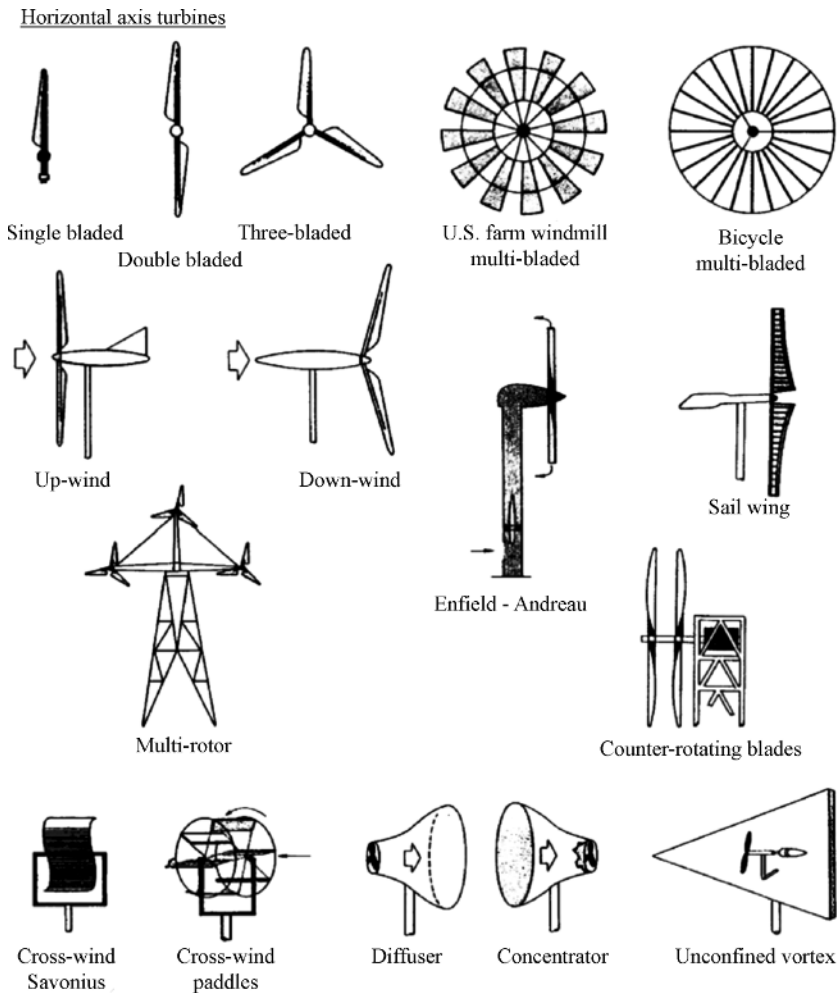
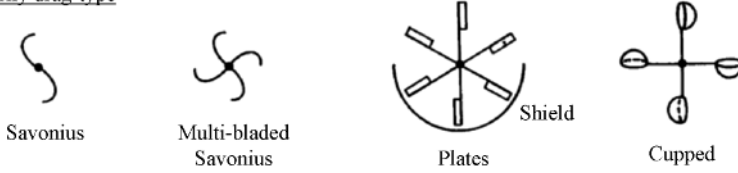
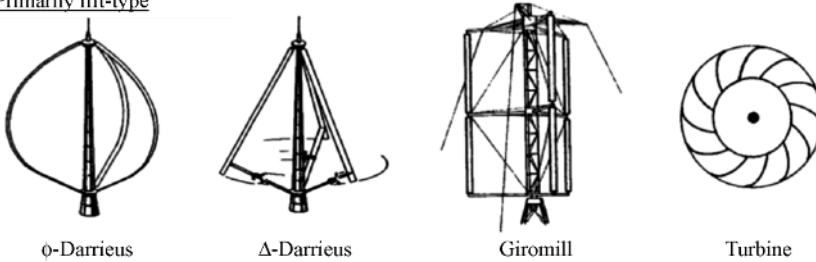

Figure 1.6 Various concepts for horizontal axis turbines (Eldridge, 1980)

Primarily drag-type



Primarily lift-type



Combinations

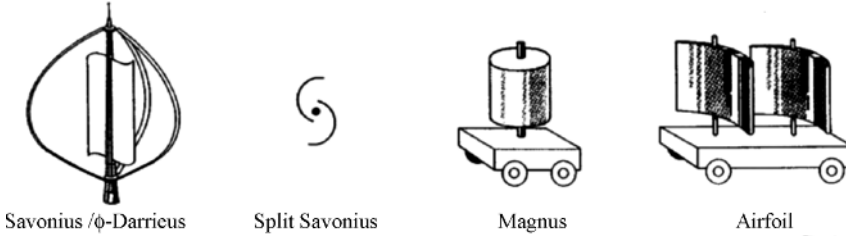

Others

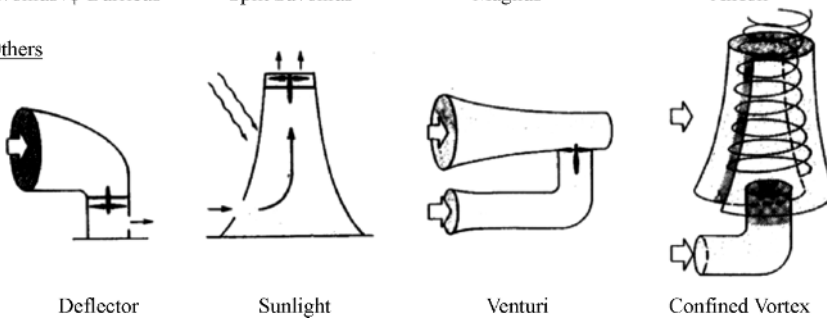

Figure 1.7 Various concepts for vertical axis turbines (Eldridge, 1980)

1.2 History of Wind Energy

It is worthwhile to consider some of the history of wind energy. The history serves to illustrate the issues that wind energy systems still face today, and provides insight into why turbines look the way they do. In the following summary, emphasis is given to those concepts which have particular relevance today.

The reader interested in a fuller description of the history of wind energy is referred to Park (1981), Eldridge (1980), Inglis (1978), Freris (1990), Shepherd (1990), Dodge (2009), and Ackermann and Soder (2002). Golding (1977) presents a history of wind turbine design from

the ancient Persians to the mid-1950s. In addition to a summary of the historic uses of wind power, Johnson (1985) presents a history of wind electricity generation, and the US research work of the 1970–85 period on horizontal axis, vertical axis, and innovative types of wind turbines. The most recent comprehensive historical reviews of wind energy systems and wind turbines are contained in the books of Spera (1994), Gipe (1995), Harrison *et al.* (2000), and Gasch and Twele (2002). Eggleston and Stoddard (1987) give a historical perspective of some of the key components of modern wind turbines. Berger (1997) provides a fascinating picture of the early days of wind energy's re-emergence, particularly of the California wind farms.

1.2.1 A Brief History of Windmills

The first known historical reference to a windmill is from Hero of Alexandria, in his work *Pneumatics* (Woodcroft, 1851). Hero was believed to have lived either in the 1st century B.C. or the 1st century A.D. His *Pneumatics* describes a device which provides air to an organ by means of a windmill. An illustration which accompanies Hero's description is shown in Figure 1.8.

There has been some debate about whether such a windmill actually existed and whether the illustration actually accompanied the original documents. See Shepherd (1990) and Drachman (1961). One of the primary scholars on the subject, however, H. P. Vowles, (Vowles, 1932) does consider Hero's description to be plausible. One of the arguments against the early Greeks having been familiar with windmills has to do with their presumed lack of technological sophistication. However, both mechanically driven grinding stones and gearing, which would generally be used with a wind-driven rotor, were known to exist at the time of Hero. For example, Reynolds (1983) describes water-powered grinding wheels at that time. In addition, the analysis of the Antikythera mechanism (Marchant, 2006) confirms that the early Greeks had a high degree of sophistication in the fabrication and use of gears.

Apart from Hero's windmill, the next reference on the subject dates from the 9th century A.D. (Al Masudi as reported by Vowles, 1932) Windmills were definitely in use in the Persian

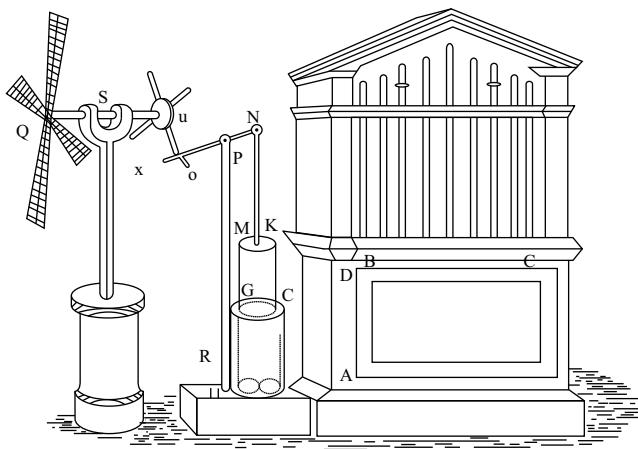

Figure 1.8 Hero's windmill (from Woodcroft, 1851)



Figure 1.9 Seistan windmill (Vowles, 1932)

region of Seistan (now eastern Iran) at that time. Al Masudi also related a story indicating that windmills were in use by 644 A.D. The Seistan windmills have continued to be used up to the present time. These windmills had vertical axis rotors, as illustrated in Figure 1.9.

Windmills made their first recorded appearance in northern Europe (England) in the 12th century but probably arrived in the 10th or 11th century (Vowles, 1930). Those windmills were considerably different in appearance to those of Seistan, and there has been considerable speculation as to if and how the Seistan mills might have influenced those that appeared later in Europe. There are no definite answers here, but Vowles 1930 has suggested that the Vikings, who traveled regularly from northern Europe to the Middle East, may have brought back the concept on one of their return trips.

An interesting footnote to this early evolution concerns the change in the design of the rotor from the Seistan windmills to those of northern Europe. The Seistan rotors had vertical axes and were driven by drag forces. As such they were inherently inefficient and particularly susceptible to damage in high winds. The northern European designs had horizontal axes and were driven by lift forces. How this transition came about is not well understood, but it was to be of great significance. It can be surmised, however, that the evolution of windmill rotor design paralleled the evolution of rigging on ships during the 1st millennium A.D., which moved progressively from square sails (primarily drag devices) to other types of rigging which used lift to facilitate tacking upwind. See, for example, Casson (1991).

The early northern European windmills all had horizontal axes. They were used for nearly any mechanical task, including water pumping, grinding grain, sawing wood, and powering tools. The early mills were built on posts, so that the entire mill could be turned to face the wind (or yaw) when its direction changed. These mills normally had four blades. The number and size of blades presumably was based on ease of construction as well as an empirically determined efficient solidity (ratio of blade area to swept area). An example of a post mill can be seen in Figure 1.10.

The wind continued to be a major source of energy in Europe through the period just prior to the Industrial Revolution, but began to recede in importance after that time. The reason that wind energy began to disappear is primarily attributable to its non-dispatchability and its non-transportability. Coal had many advantages which the wind did not possess. Coal could be transported to wherever it was needed and used whenever it was desired. When coal was used to fuel a steam engine, the output of the engine could be adjusted to suit the load. Water power,



Figure 1.10 Post mill (http://en.wikipedia.org/wiki/File:Oldland_Mill.jpg)

which has some similarities to wind energy, was not eclipsed so dramatically. This is no doubt because water power is, to some extent, transportable (via canals) and dispatchable (by using ponds as storage).

Prior to its demise, the European windmill had reached a high level of design sophistication. In the later mills (or ‘smock mills’), such as the one shown in Figure 1.11, the majority of the mill was stationary. Only the top would be moved to face the wind. Yaw mechanisms included



Figure 1.11 European smock mill (Hills, 1994). Reproduced by permission of Cambridge University Press

both manually operated arms and separate yaw rotors. Blades had acquired somewhat of an airfoil shape and included some twist. The power output of some machines could be adjusted by an automatic control system. This was the forerunner of the system used by James Watt on steam engines. In the windmill's case a fly ball governor would sense when the rotor speed was changing. A linkage to a tentering mechanism would cause the upper millstone to move closer or farther away from the lower one, letting in more or less grain to grind. Increasing the gap would result in more grain being ground and thus a greater load on the rotor, thereby slowing it down and vice versa. See Stokhuyzen (1962) for details on this governor as well as other features of Dutch windmills.

One significant development in the 18th century was the introduction of scientific testing and evaluation of windmills. The Englishman John Smeaton, using such apparatus as illustrated in Figure 1.12, discovered three basic rules that are still applicable:

- The speed of the blade tips is ideally proportional to the speed of wind.
- The maximum torque is proportional to the speed of wind squared.
- The maximum power is proportional to the speed of wind cubed.

The 18th century European windmills represented the culmination of one approach to using wind for mechanical power and included a number of features which were later incorporated into some early electricity-generating wind turbines.

As the European windmills were entering their final years, another variant of windmill came into widespread use in the United States. This type of windmill, illustrated in Figure 1.13, was most notably used for pumping water, particularly in the west. They were used on ranches for cattle and to supply water for the steam railroads. These mills were distinctive for their multiple blades and are often referred to as 'fan mills'. One of their most significant features was a simple but effective regulating system. This allowed the turbines to run unattended for long periods. Such regulating systems foreshadowed the automatic control systems which are now an integral part of modern wind turbines.

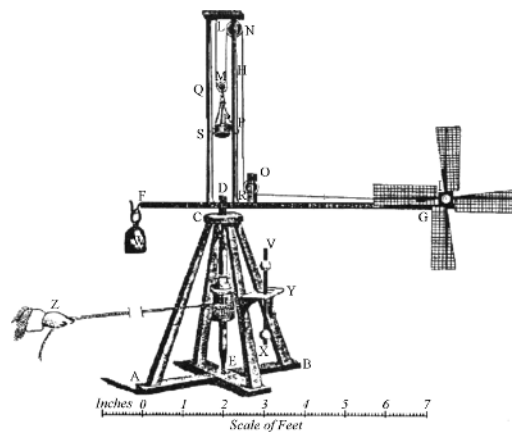

Figure 1.12 Smeaton's laboratory windmill testing apparatus



Figure 1.13 American water-pumping windmill design (US Department of Agriculture)

1.2.2 Early Wind Generation of Electricity

The initial use of wind for electricity generation, as opposed to mechanical power, included the successful commercial development of small wind generators and research and experiments using large wind turbines.

When electrical generators appeared towards the end of the 19th century, it was reasonable that people would try to turn them with a windmill rotor. In the United States, the most notable early example was built by Charles Brush in Cleveland, Ohio in 1888. The Brush turbine did not result in any trend, but in the following years, small electrical generators did become widespread. These small turbines, pioneered most notably by Marcellus Jacobs and illustrated in Figure 1.14, were, in some ways, the logical successors to the water-pumping fan mill. They were also significant in that their rotors had three blades with true airfoil shapes and began to resemble the turbines of today. Another feature of the Jacobs turbine was that it was typically incorporated into a complete, residential scale power system, including battery storage. The Jacobs turbine is considered to be a direct forerunner of such modern small turbines as the Bergey and Southwest Windpower machines. The expansion of the central electrical grid under the auspices of the Rural Electrification Administration during the 1930s marked the beginning of the end of the widespread use of small wind electric generators, at least for the time being.

The first half of the 20th century also saw the construction or conceptualization of a number of larger wind turbines which substantially influenced the development of today's technology. Probably the most important sequence of turbines was in Denmark. Between 1891 and 1918 Poul La Cour built more than 100 electricity generating turbines in the 20–35 kW size range. His design was based on the latest generation of Danish smock mills. One of the more remarkable features of the turbine was that the electricity that was generated was used to produce hydrogen, and the hydrogen gas was then used for lighting. La Cour's turbines were followed by a number of turbines made by Lykkegaard Ltd. and F. L. Smidth & Co prior to World War II. These ranged in size from 30 to 60 kW. Just after the war, Johannes



Figure 1.14 Jacobs turbine (Jacobs, 1961)

Juul erected the 200 kW Gedser turbine, illustrated in Figure 1.15, in southeastern Denmark. This three-bladed machine was particularly innovative in that it employed aerodynamic stall for power control and used an induction generator (squirrel cage type) rather than the more conventional (at the time) synchronous generator. This type of induction generator is much simpler to connect to the grid than is a synchronous generator. Stall is also a simple way to control power. These two concepts formed the core of the strong Danish presence in wind energy in the 1980s (see <http://www.risoe.dk/> and <http://www.windpower.dk/> for more details on wind energy in Denmark). One of the pioneers in wind energy in the 1950s was Ulrich Hütter in Germany (Dörner, 2002). His work focused on applying modern aerodynamic principles to wind turbine design. Many of the concepts he worked with are still in use in some form today.

In the United States, the most significant early large turbine was the Smith–Putnam machine, built at Grandpa’s Knob in Vermont in the late 1930s (Putnam, 1948). With a diameter of 53.3 m and a power rating of 1.25 MW, this was the largest wind turbine ever built up until that time and for many years thereafter. This turbine, illustrated in Figure 1.16, was also significant in that it was the first large turbine with two blades. In this sense it was a predecessor of the two-bladed turbines built by the US Department of Energy in the late 1970s and early 1980s. The turbine was also notable in that the company that built it, S. Morgan Smith, had long experience in hydroelectric generation and intended to produce a commercial line of wind machines. Unfortunately, the Smith–Putnam turbine was too large, too early, given the level of understanding of wind energy engineering. It suffered a blade failure in 1945, and the project was abandoned.



Figure 1.15 Danish Gedser wind turbine. Reproduced by permission of Danish Wind Turbine Manufacturers

1.2.3 The Re-Emergence of Wind Energy

The re-emergence of wind energy can be considered to have begun in the late 1960s. The book *Silent Spring* (Carson, 1962) made many people aware of the environmental consequences of industrial development. *Limits to Growth* (Meadows *et al.*, 1972) followed in the same vein, arguing that unfettered growth would inevitably lead to either disaster or change. Among the culprits identified were fossil fuels. The potential dangers of nuclear energy also became more public at this time. Discussion of these topics formed the backdrop for an environmental movement which began to advocate cleaner sources of energy.

In the United States, in spite of growing concern for environmental issues, not much new happened in wind energy development until the Oil Crises of the mid-1970s. Under the Carter administration, a new effort was begun to develop 'alternative' sources of energy, one of which was wind energy. The US Department of Energy (DOE) sponsored a number of projects to foster the development of the technology. Most of the resources were allocated to large machines, with mixed results. These machines ranged from the 100 kW (38 m diameter) NASA MOD-0 to the 3.2 MW Boeing MOD-5B with its 98 m diameter. Much interesting data was generated but none of the large turbines led to commercial projects. DOE also supported development of some small wind turbines and built a test facility for small machines at Rocky



Figure 1.16 Smith–Putnam wind turbine (Eldridge, 1980)

Flats, Colorado. A number of small manufacturers of wind turbines also began to spring up, but there was not a lot of activity until the late 1970s (see Dodge, 2009).

The big opportunities occurred as the result of changes in the utility regulatory structure and the provision of incentives. The US federal government, through the Public Utility Regulatory Policy Act of 1978, required utilities (1) to allow wind turbines to connect with the grid and (2) to pay the ‘avoided cost’ for each kWh the turbines generated and fed into the grid.

The actual avoided cost was debatable, but in many states utilities would pay enough that wind generation began to make economic sense. In addition, the federal government and some states provided investment tax credits to those who installed wind turbines. The state which provided the best incentives, and which also had regions with good winds, was California. It was now possible to install a number of small turbines together in a group (‘wind farm’), connect them to the grid, and make some money.

The California wind rush was on. Over a period of a few years, thousands of wind turbines were installed in California, particularly in the Altamont Pass, San Geronio Pass, and Tehachapi. A typical installation is shown in Figure 1.17. The installed capacity reached approximately 1500 MW. The early years of the California wind rush were fraught with difficulties, however. Many of the machines were essentially still prototypes, and not yet up to the task. An investment tax credit (as opposed to a production tax credit) is arguably not the best way to encourage the development and deployment of productive machines, especially when there is no means for certifying that machines will actually perform as the manufacturer claims.



Figure 1.17 California wind farm (National Renewable Energy Laboratory)

When the federal tax credits were withdrawn by the Reagan administration in the early 1980s, the wind rush collapsed.

Wind turbines installed in California were not limited to those made in the United States. In fact, it was not long before Danish turbines began to have a major presence in the California wind farms. The Danish machines also had some teething problems in California, but in general they were closer to production quality than were their US counterparts. When all the dust had settled after the wind rush had ended, the majority of US manufacturers had gone out of business. The Danish manufacturers had restructured or merged, but had in some way survived.

During the 1990s, a decade which saw the demise (in 1996) of the largest US manufacturer, Kennetech Windpower, the focal point of wind turbine manufacturing definitively moved to Europe, particularly Denmark and Germany. Concerns about global warming and continued apprehension about nuclear power resulted in a strong demand for more wind generation there and in other countries as well. The 21st century has seen some of the major European suppliers establish manufacturing plants in other countries, such as China, India, and the United States.

In recent times, the size of the largest commercial wind turbines, as illustrated in Figure 1.18, has increased from approximately 25 kW to 6 MW, with machines up to 10 MW under design. The total installed capacity in the world as of the year 2009 was about 115 000 MW, with the majority of installations in Europe. Offshore wind energy systems were also under active development in Europe, with about 2000 MW installed as of 2008. Design standards and machine certification procedures have been established, so that the reliability and performance are far superior to those of the 1970s and 1980s. The cost of energy from wind has dropped to the point that in many sites it is nearly competitive with conventional sources, even without incentives. In those countries where incentives are in place, the rate of development is quite strong.

1.2.4 Technological Underpinnings of Modern Wind Turbines

Wind turbine technology, dormant for many years, awoke at the end of the 20th century to a world of new opportunities. Developments in many other areas of technology were adapted to

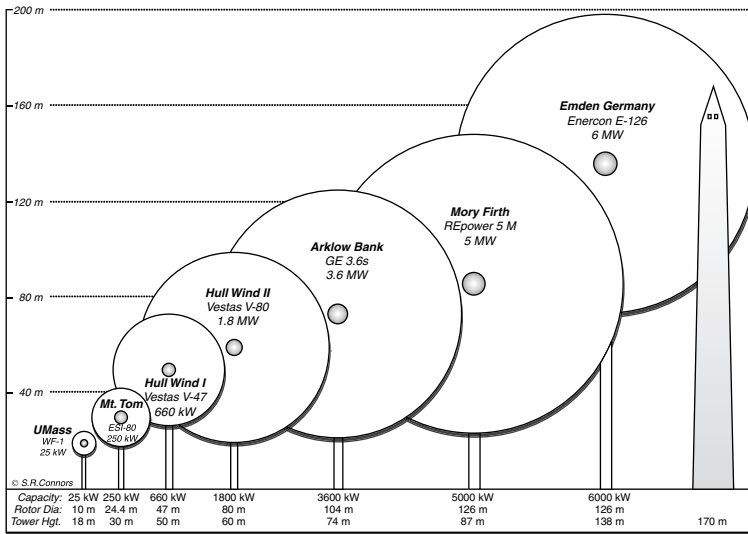

Figure 1.18 Representative size, height, and diameter of wind turbines (Steve Connors, MIT)

wind turbines and have helped to hasten their re-emergence. A few of the many areas which have contributed to the new generation of wind turbines include materials science, computer science, aerodynamics, analytical design and analysis methods, testing and monitoring, and power electronics. Materials science has brought new composites for the blades and alloys for the metal components. Developments in computer science facilitate design, analysis, monitoring, and control. Aerodynamic design methods, originally developed for the aerospace industry, have now been adapted to wind turbines. Analytical design and analysis methods have now developed to the point where it is possible to have a much clearer understanding of how a new design should perform than was previously possible. Testing and monitoring using a vast array of commercially available sensors and modern data collection and analysis equipment allow designers to better understand how the new turbines actually perform. Power electronics is now widely used with wind turbines. Power electronic devices can help connect the turbine's generator smoothly to the electrical network; allow the turbine to run at variable speed, producing more energy, reducing fatigue damage, and benefit the utility in the process; facilitate operation in a small, isolated network; and transfer energy to and from storage.

1.2.5 Trends

Wind turbines have evolved a great deal over the last 35 years. They are more reliable, more cost effective, and quieter. It cannot be concluded that the evolutionary period is over, however. It should still be possible to reduce the cost of energy at sites with lower wind speeds. Turbines for use in remote communities still remain to be made commercially viable. The world of offshore wind energy is just in its infancy. There are tremendous opportunities in offshore locations but many difficulties to be overcome. As wind energy comes to supply an ever larger fraction of the world's electricity, the issues of intermittency, transmission, and storage must be revisited.

There will be continuing pressure for designers to improve the cost effectiveness of turbines for all applications. Improved engineering methods for the analysis, design, and for mass-produced manufacturing will be required. Opportunities also exist for the development of new materials to increase wind turbine life. Increased consideration will need to be given to the requirements of specialized applications. In all cases, the advancement of the wind industry represents an opportunity and challenge for a wide range of disciplines, especially including mechanical, electrical, materials, aeronautical, controls, ocean and civil engineering as well as computer science.

References

- Ackermann, T. and Soder, L. (2002) An overview of wind energy-status 2002. *Renewable and Sustainable Energy Reviews*, **6**, 67–127.
- Berger, J. J. (1997) *Charging Ahead: The Business of Renewable Energy and What it Means for America*. University of California Press, Berkeley, CA.
- Carson, R. (1962) *Silent Spring*. Houghton Mifflin, New York.
- Casson, L. (1991) *The Ancient Mariners: Seafarers and Sea Fighters of the Mediterranean in Ancient Times*. Princeton University Press, Princeton, NJ.
- Danish Wind Turbine Manufacturers (2001) <http://www.windpower.dk>.
- Dodge, D. M. (2009) Illustrated history of wind power development, <http://telosnet.com/wind>.
- Dörner, H. (2002) *Drei Welten- ein Leben: Prof. Dr Ulrich Hütter*. Heilbronn.
- Drachman, A. G. (1961) Heron's windmill. *Centaurus*, **7**(2), 145–151.
- Eggleston, D. M. and Stoddard, F. S. (1987) *Wind Turbine Engineering Design*. Van Nostrand Reinhold, New York.
- Eldridge, F. R. (1980) *Wind Machines*, 2nd edition. Van Nostrand Reinhold, New York.
- Freris, L. L. (1990) *Wind Energy Conversion Systems*. Prentice Hall, New York.
- Gasch, R. and Twele, J. (2002) *Wind Power Plants*. James & James, London.
- Gipe, P. (1995) *Wind Energy Comes of Age*. John Wiley & Sons, Inc., New York.
- Golding, E. W. (1977) *The Generation of Electricity by Wind Power*. E. & F. N. Spon, London.
- Harrison, R., Hau, E. and Snel, H. (2000) *Large Wind Turbines: Design and Economics*. John Wiley & Sons, Ltd, Chichester.
- Hills, R. L. (1994) *Power from Wind*. Cambridge University Press, Cambridge, UK.
- Inglis, D. R. (1978) *Windpower and Other Energy Options*. University of Michigan Press, Ann Arbor.
- Jacobs, M. L. (1961) Experience with Jacobs wind-driven electric generating plant, 1931–1957. *Proc. of the United Nations Conference on New Sources of Energy*, **7**, 337–339.
- Johnson, G. L. (1985) *Wind Energy Systems*. Prentice Hall, Englewood Cliffs, NJ.
- Le Gourieres, D. (1982) *Wind Power Plants*. Pergamon Press, Oxford.
- Marchant, J. (2006) In Search of Lost Time. *Nature*, **444**, 534–538.
- McGowan, J. G. and Connors, S. R. (2000) Windpower: a turn of the century review. *Annual Review of Energy and the Environment*, **25**, 147–197.
- Meadows, D. H., Meadows, D. L., Randers, J. and Behrens III, W. W. (1972) *The Limits to Growth*. Universe Books, New York.
- Nelson, V. (1996) *Wind Energy and Wind Turbines*. Alternative Energy Institute, Canyon, TX.
- Paraschivou, I. (2002) *Wind Turbine Design: With Emphasis on Darrieus Concept*. Polytechnic International Press, Montreal.
- Park, J. (1981) *The Wind Power Book*. Cheshire Books, Palo Alto, CA.
- Price, T. J. (2006) UK Large-scale wind power programme from 1970 to 1990: The Carmarthen Bay experiments and the Musgrove vertical-axis turbines. *Wind Engineering*, **30**(3), 225–242.
- Putnam, P. C. (1948) *Power From the Wind*. Van Nostrand Reinhold, New York.
- Reynolds, T. S. (1983) *Stronger than a Hundred Men: A History of the Vertical Water Wheel*. Johns Hopkins University Press, Baltimore.
- Shepherd, D. G. (1990) *The Historical Development of the Windmill*, NASA Contractor Report 4337, DOE/NASA 52662.
- SNL (2009) *VAWT Technology*, Sandia National Laboratories, <http://sandia.gov/wind/topical.htm#VAWTARCHIVE>.

- Spera, D. A. (Ed.) (1994) *Wind Turbine Technology: Fundamental Concepts of Wind Turbine Engineering*. ASME Press, New York.
- Stokhuyzen, F. (1962) *The Dutch Windmill*, available at <http://www.nt.ntnu.no/users/haugwarb/DropBox/The Dutch Windmill Stokhuyzen 1962.htm>.
- US Department of Energy (1979) *Wind Energy Innovative Systems Conference Proceedings*. Solar Energy Research Institute (SERI).
- US Department of Energy (1980), *SERI Second Wind Energy Innovative Systems Conference Proceedings*, Solar Energy Research Institute (SERI).
- van Bussel, G. J. W. (2007) The science of making more torque from wind: diffuser experiments and theory revisited. *Journal of Physics: Conference Series*, **75**, 1–11.
- Vowles, H. P. (1930) An inquiry into the origins of the windmill. *Journal of the Newcomen Society*, **11**, 1–14.
- Vowles, H. P. (1932) Early evolution of power engineering. *Isis*, **17**(2), 412–420.
- Woodcroft, B. (1851) Translation from the Greek of *The Pneumatics of Hero of Alexandria*. Taylor Walton and Maberly, London. Available at: <http://www.history.rochester.edu/steam/hero/>.